

REPORT : LAND DEVELOPMENT CONTROL AUTHORITY – 5TH MAY 2021**REPORT OF HEAD OF PLANNING AND BUILDING CONTROL****Minor Amendment of Plans in Conservation Areas and Listed Buildings****1. Introduction**

- 1.1 The purpose of this paper is to review the decision of the Land Development Control Authority (LDCA) in February 2017 when it was decided that the Planning Officer would consult Heritage Society and Saint Helena National Trust (SHNT) on minor variation proposals submitted for consideration affecting development of listed buildings or development within a conservation area where these stakeholders have made representation to the initial development proposal. This was recently brought to the attention of the Planning Officers by the Heritage Society following the publication of the LDCA meeting agenda in April on items “for information” that was being reported for decision taken by the Chief Planning Officer under delegated authority to approve number of Minor Variation applications in respect of developments that had been approved and the applicant had sought minor changes to details of the buildings.
- 1.2 Number of development being reported for minor variation applications included developments where the Heritage Society had made representation to the initial proposal. The Heritage Society considers that it should have been consulted on the minor variation applications as these developments fall within the February 2017 LDCA decision. The Society also considers that “Discharge of Conditions” request also fall within the 2017 LDCA decision and similarly the Chief Planning Officer should consult with the Society and SHNT on the Discharge of Condition request where representation has been made on the development application.

2. Background

- 2.1 Following the email alert from the Heritage Society on the publication of the LDCA meeting Agenda and requesting to address the Authority in respect of the Item on the Agenda for information only, officer checked the Minutes of the Meeting for the January and February 2017 meetings. There is note appended to the February 2017 meeting Minutes relating to this from the locum Head of Planning and Development Control. This notes provides some background, but there is no corresponding Minute on this decision. The content of the note states that there was a concern by the stated stakeholders that minor variations of inferior design and detail undermining the integrity of the heritage, historic buildings and conservation value of the designated areas were being approved by the planning officers. This related to developments where representation was made to the initial proposal by the stakeholders and that the stakeholders should have been on the minor changes to the design, details and materials being sought by the applicants.
- 2.2 Whilst there is an appended note to the Minute of the February meeting, the note being dated January 2017, there is no related mention in the Minutes to acknowledge the

decision. However, as issue has been raised, it is appropriate to review this issues and to consider whether the decision of the LDCA in this respect should be revoked or that there is still some merit for this to be continued and the previous decision can be agreed for the record.

3. Current Practice

3.1 It is difficult provide any assessment of the practice by previous senior planning officer and/or to qualitative assessment of these practices and decision and neither should I be judging previous decision, I consider this previous decision of the LDCA to be cumbersome and time consuming and considering the workload and pressures for urgent decision in many cases not very practical. However, as a general rule, any minor variation applications, particularly those affecting heritage and the historic environment should be an improvement of design and details. Where this is not the case, the application for minor variation is refused and the applicant is advised to submit new full development application and that is then subject to the formal process for decision following a period of consultation with stakeholder and public.

3.2 It is my professional view that whilst the Planning Service welcome the input from the stakeholder on the design and details of proposed development and where suggestions are made to improve design and details of the development, then these are taken on board. However it is not considered necessary or appropriate that on every request for minor variation as per this previous decision, officers should be obliged consult with SHNT and Heritage Society. This matter should be left to the professional assessment of the Planning Officers and their discretion to determine whether input from these stakeholders would be necessary and that it can add value to the decision making.

3.3 This concern by representative of Heritage Society has been triggered by the reporting of two recent decision for Minor Variation and Discharge of Condition related to design change for the Cable Landing Station Building in Rupert’s Bay and the details of the handrail for the entrance steps to the Castle Building respectively. For the benefit of the Authority and general interest of the stakeholder and in the spirit of openness and transparency the details of the approved details are enclosed in this report.

3.4 Cable Landing Station Building Details

Original Approved Design

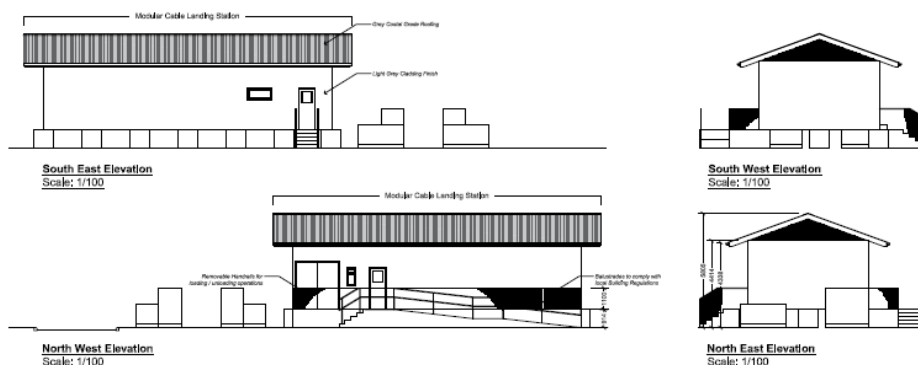

- 3.5 The need was change in design was prompted by the development for the Container Freight Development to enable the Port Security Officer to have clear line of vision of the Wharf Area from the first floor observation. The Cable Landing station roof level was obscuring the line of vision. The roof design now proposed overcome this issue and it is considered that the proposal does not in any way compromises the design aesthetic.

Approved Minor Variation

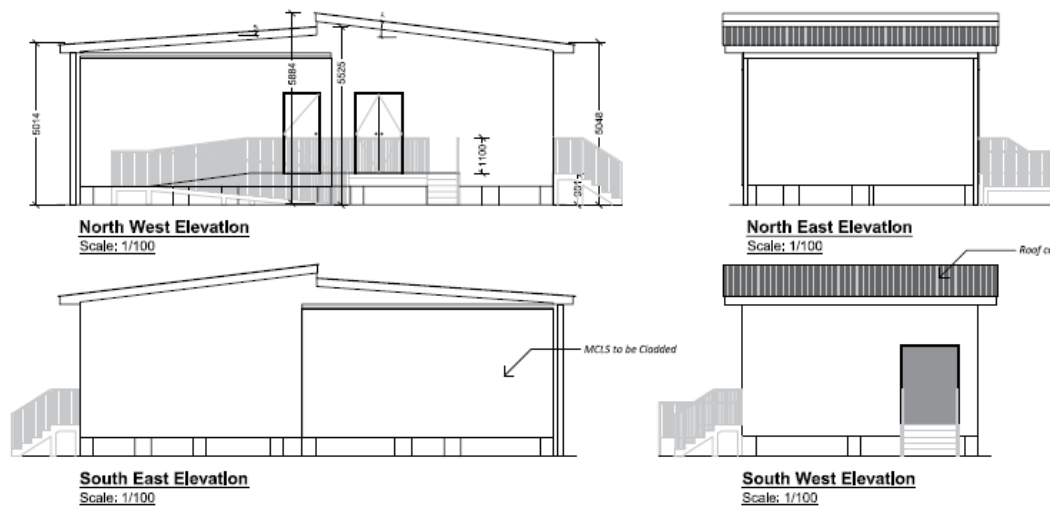

- 3.6 Handrail Castle Building

Original Approved Design

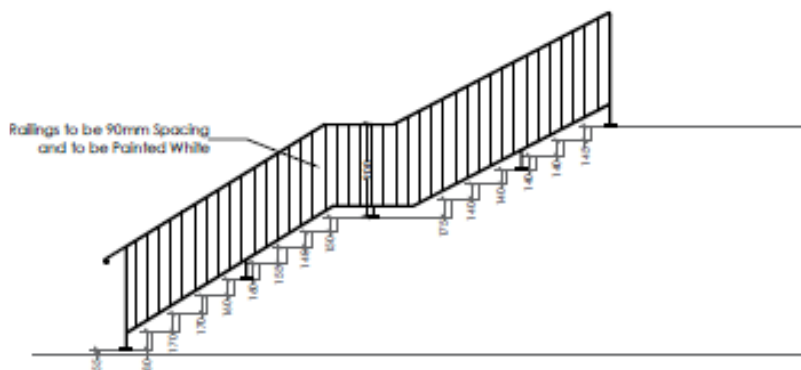

- 3.7 The original proposal was for round cast iron handrail, but Members considered that the design as proposed was not of design and quality appropriate for this civic building and could benefit from a further consideration. The detail of the design was a condition of the development permission granted. The applicant submitted details for the Discharge of the Condition which was considered to meet with the view expressed by Members and these design details were approved.

Approved Discharge of Condition

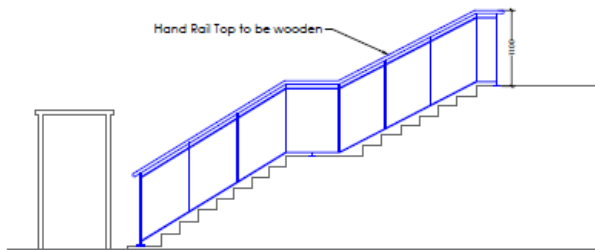

Cross-Section of the Handrail Design

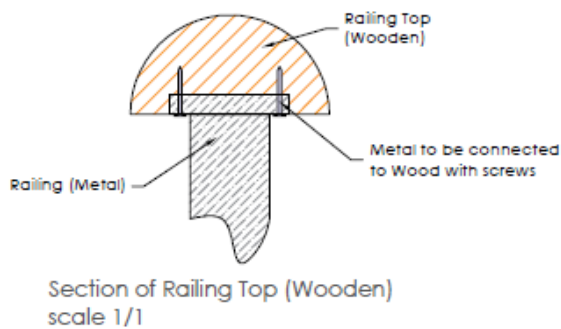

4. Conclusion and Recommendation

- 4.1 In view of the issues raised by the representative of the Heritage Society on the decision of the LDCA in January 2017, attached to Minutes of the February 2017 meeting, it is considered that planning officers should not be required to comply by this earlier decision. As demonstrated by the examples of the recent decisions of design details that have been approved that officer are able to make reasoned decision on the assessment of design details and proposed changes. It should be left to the discretion of the Planning Officer to determine whether there would be further value in seeking advice from stakeholder.
- 4.2 In light of the details set out above and assessment of the process and procedures, it is recommended that the Authority revoke the decision previously made to consult with Saint Helena National Trust and the Heritage Society on future Minor Variation sought by applicants on approved details and discharge of design related conditions for development applications were these stakeholder have made representation and that it should be left to the discretion of the Planning Officer to consider if the Stakeholder should be consulted.